

yy y 0go r q/hqco 0go

8

7

6

5

8

7

6

5

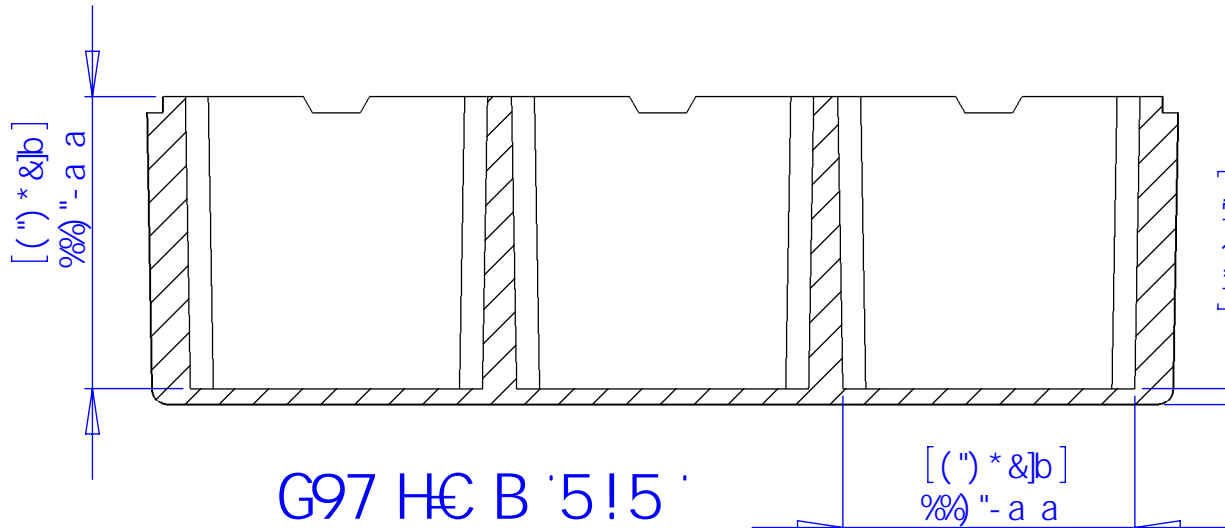
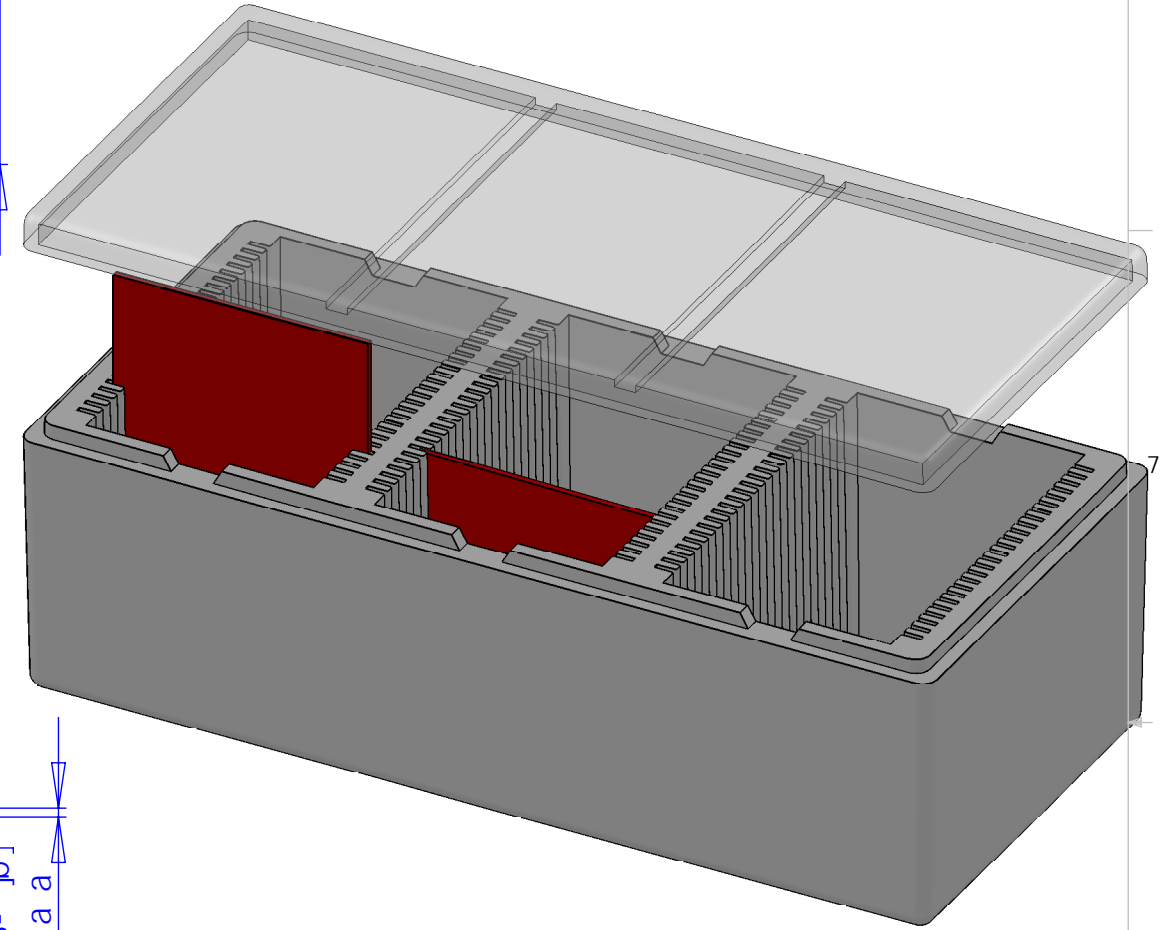
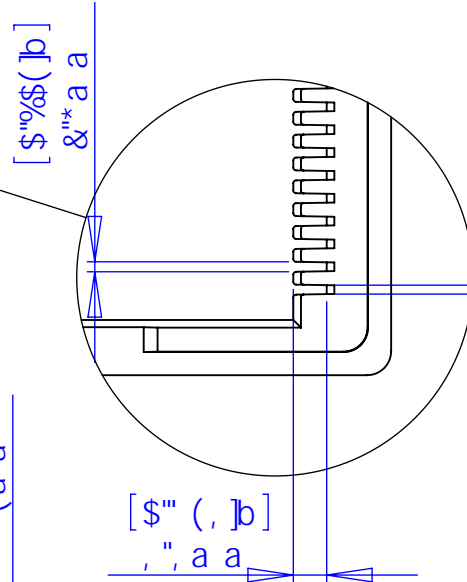
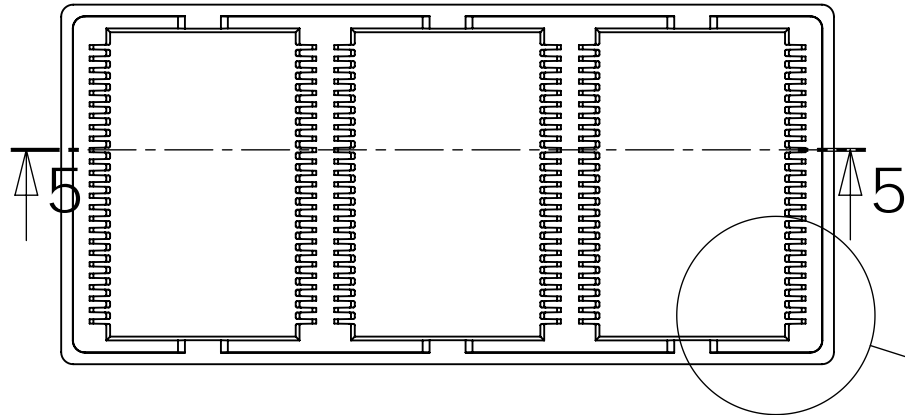
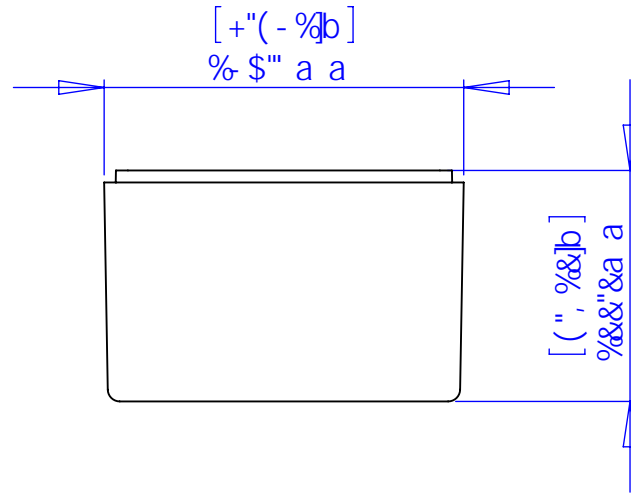
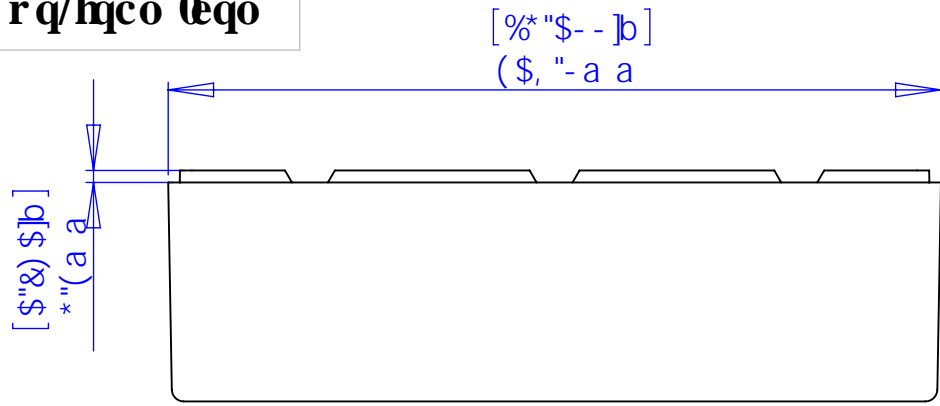

G97 H€ B '5!5' G7 5 @9% . "

8 9H5 @6' G7 5 @9% . &

BchY.

%&'A UHYf]U`Hc`VY`* ([#` XYbg]mf("\$`V#zh Ł'9DG &Ł'%8Y[fYY`8fUZiHMD ' Ł:]`YhfUX]i g`bchW[h]WJ`

DFCDF-945FM5B87CB: 89BH5@ H:9 B: CFA 5HC B 7 CBH5 B98 B H:6 8F5K B: :GH:9GC @DFC.D9F.HMC: Vgo r q'Rrcule'E q0'Kpe0 5BM F9DFC81 7HC B B D5FHCF 5G5 K <C @ K H:C I HH:9K FHH9B D9FA GGC B C: Vgo r q'Rrcule'E q0'Kpe0 G DFC <6+98"

B9LH5GGM	I G98 C B	5DD@7 5HC B	8C BC HG7 5 @98F5K B:
----------	-----------	-------------	-----------------------

I B @GGC H:9FK @9 GD97 ±98.	B5A 9	85H9	Vgo r q'Rrcule'E q0'Kpe0
8A 98GC BG5F9 B B7 <9G HC @F5B7 9G :F57 HC B5 @± 5B: I @5F: A 57 <± 698 B ± HK C D @57 9897 A 5 @± H:F99D @57 9897 A 5 @±	8F5K B	>F< + #/ & # & \$ % &	
BHFDF9H: 9CA 9HF 7 HC @F5B7 B: D9F. A 5HF 5 @	7 <97 ?98	9B: '5DDF"	HH @. +) G () * &
	9B: '5DDF"	A: : '5DDF"	
	E "5"	7 C A A 9BHG	
			GAP 8K ; ""BC "
			F9J
			G7 5 @9% (
			G <99H % C : %