

G97 HC B '616

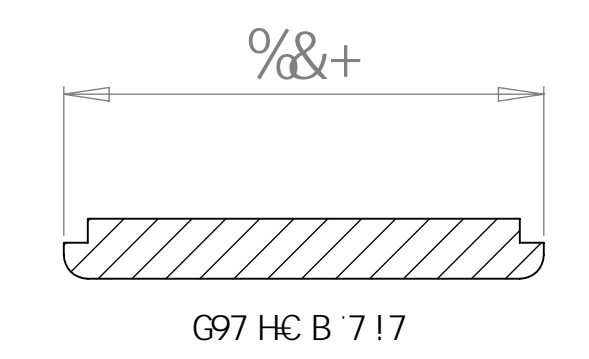
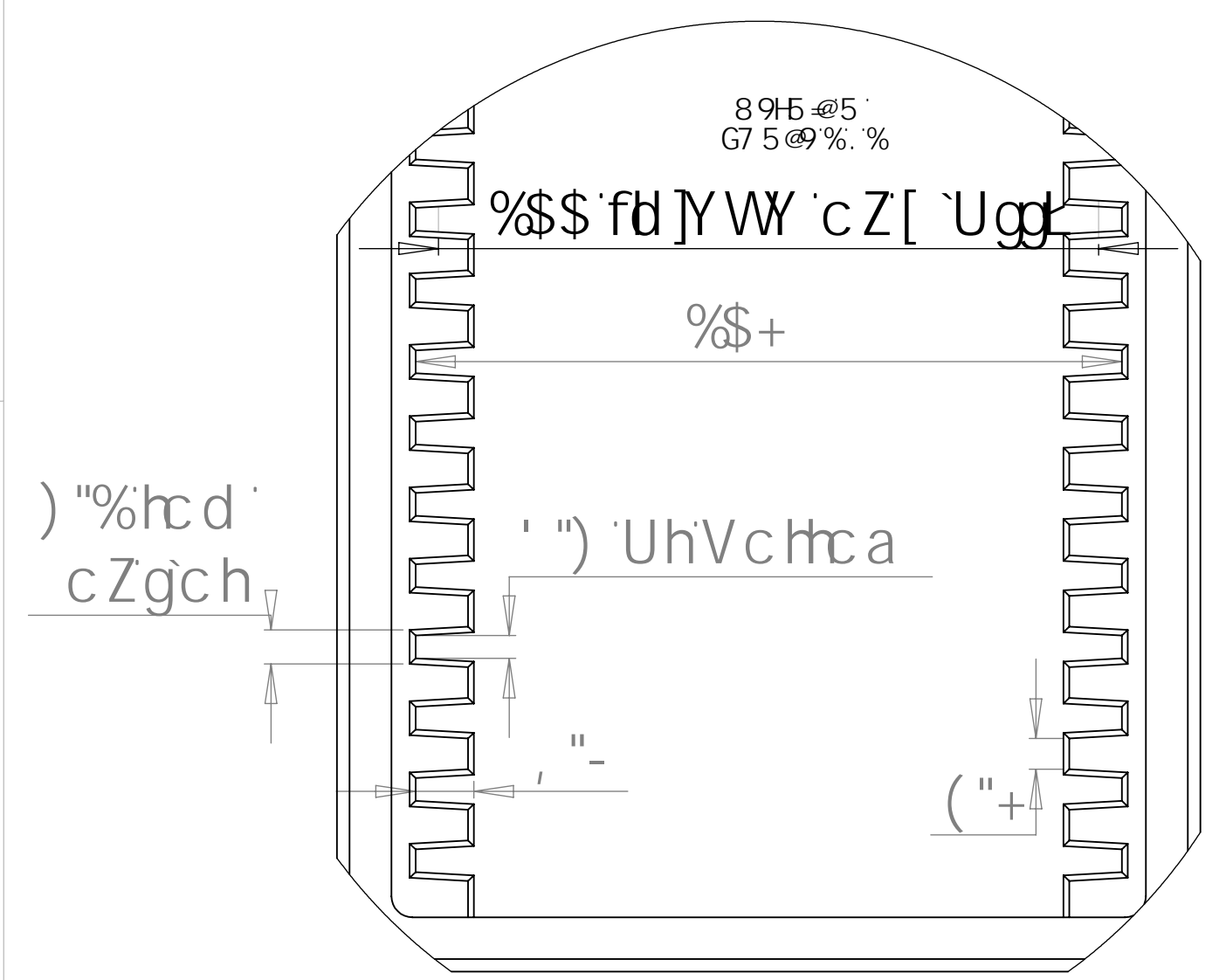
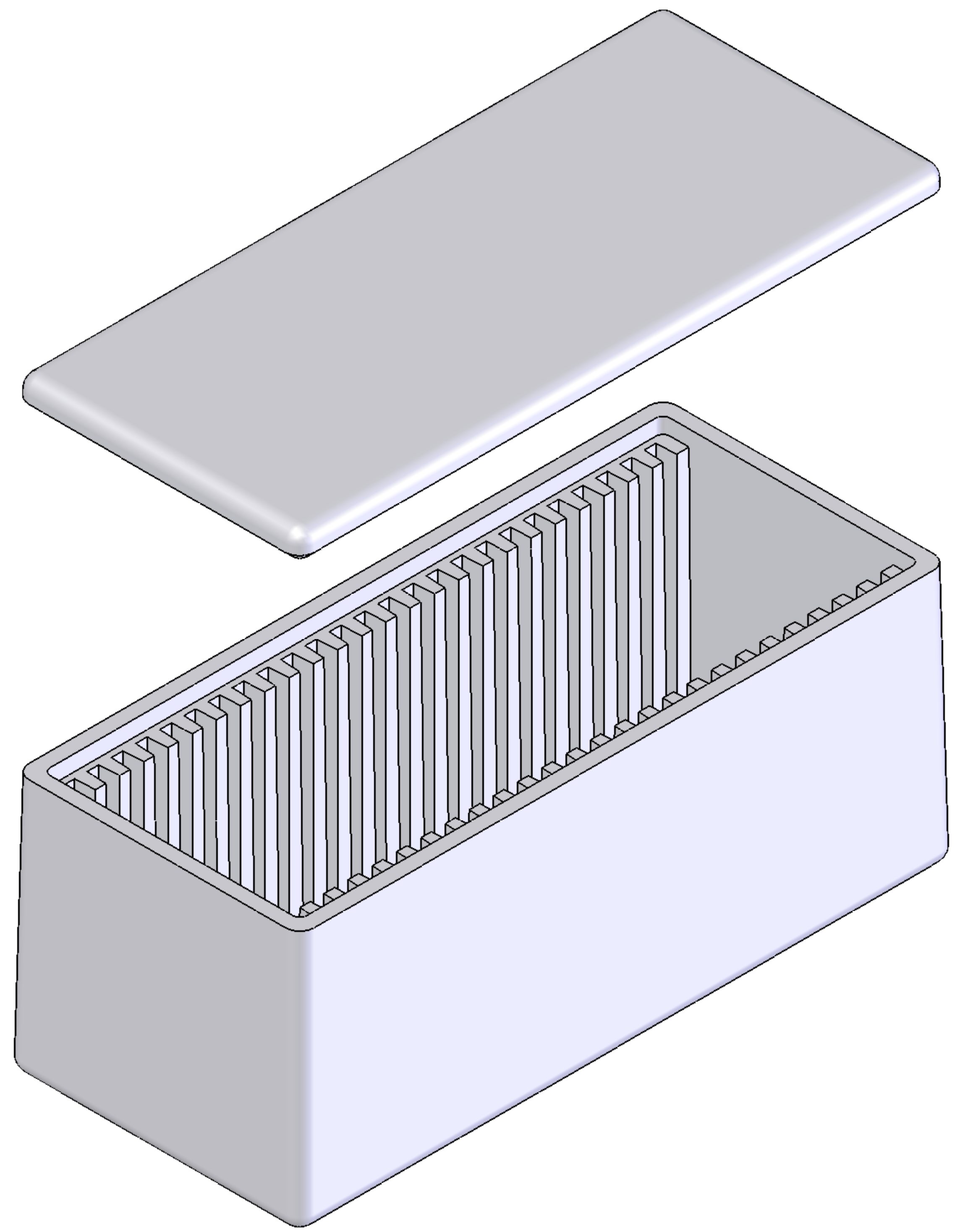

BchY.

%&A UHY f]U`Hc`VY`* ([#`XYbg]mf("\$`V`#Zi L`9DGz
\`f]b_U[Y`]g`"%&a a`dYf&)"(a a
 &L`C`d`h`c`b`U`a` UHY f]U`* ([#`XYbg]m9D9z
\`f]b_U[Y`]g`"+) a a`dYf&)"(a a`z`b`Wi`XYX`]b`XYg][b
 ' L`%8Y[fYY`YI`hY`f]c`fz`%#&`8Y[fYY`b`hY`f]c`f`8fU`Zi`HMD

DFC DF 95FM5B8 7CB: 89BH5@

Hk 9 B: CFA 5HC B 7C BH5 B98 B Hk 6
 8F5K B: GHK 9CC @DFC D9FHC:
 H'a dc D'UgW7 c" bW 5BM
 F9DFC 8I 7HC B B D5FHC F 5G5 K <C @
 K Hk CI Hk 9K F H9B D9FA GGC B C:
 H'a dc D'UgW7 c" bW 6
 DFC < 6+98"

I BAKCC H 9K @DZ97 + 98		B5A 9	851P	Vgo r q'Rrcuve'Eq.'Kpe0
B4 98C BCS19 B A]b YWg	8F5K B	: b]f" #5		HH9.
IC 9F5B 7% F57HC B59e	7<9798	: b]f" #5		
SB: 1 851 A 512 2 698B + K C D87 9897 A 5# 2 H F99DB 79897 A 5# 2	98: 500P"	: b]f" #5		
A 51P 6#	A:: 500P"	E 5"		
BHEF9H 9CA 9H F IC 9F5B 7: 10E	%&+ B"A]YfDUf_7 h J]UJZ75`-`&- %			GAP BK: "BC"
				FQJ
				8
				5
				G7 5 @9. % &
				G-99H9C: %