

yy y 0go r q/hqco 0eqo

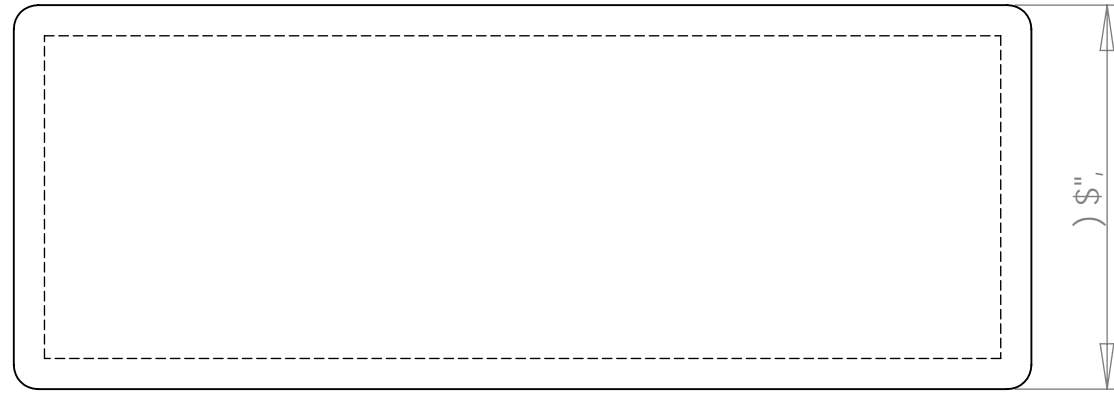

HC D'J 9K 'C : @8

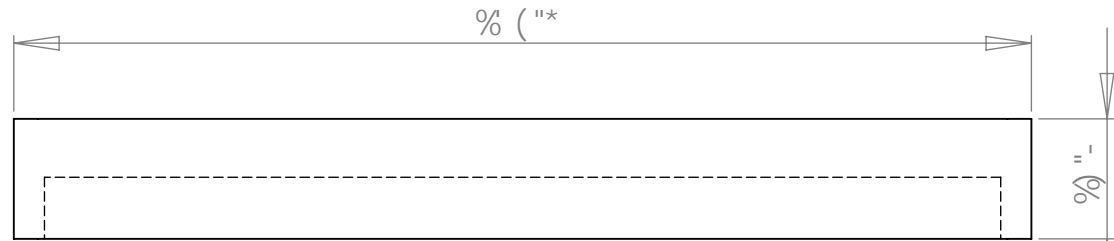

G8 9'J 9K 'C : @8

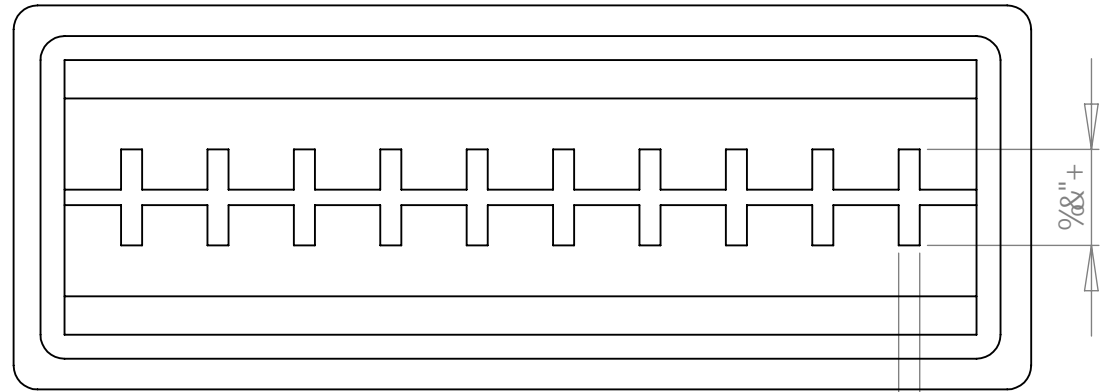

HC D'J 9K 'C : '65 G9

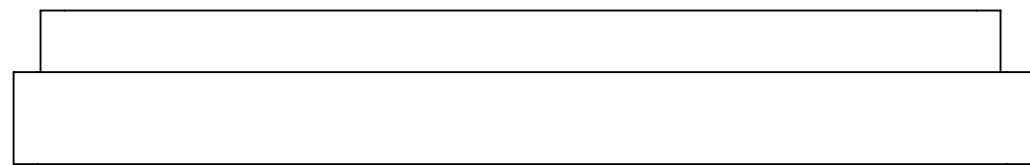

G8 9'J 9K 'C : '65 G9

HF 5 B GD 5 F 9 B H @ 8 'G < C K G  
G @ C H G : C F '% \$ ' 7 D 7 G'

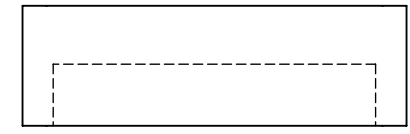

: FC BHG 8 9'J 9K 'C : @8

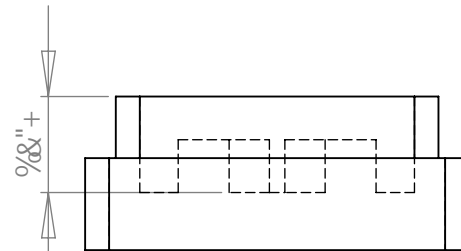

: FC BHG 8 9'J 9K 'C : '65 G9

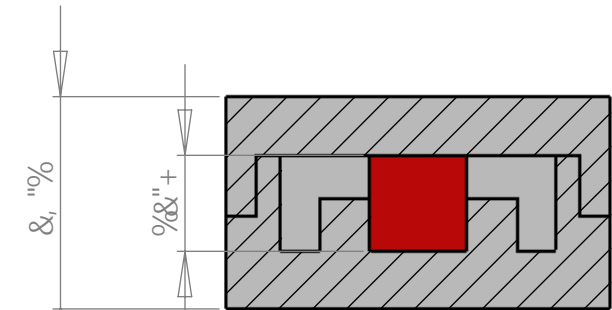
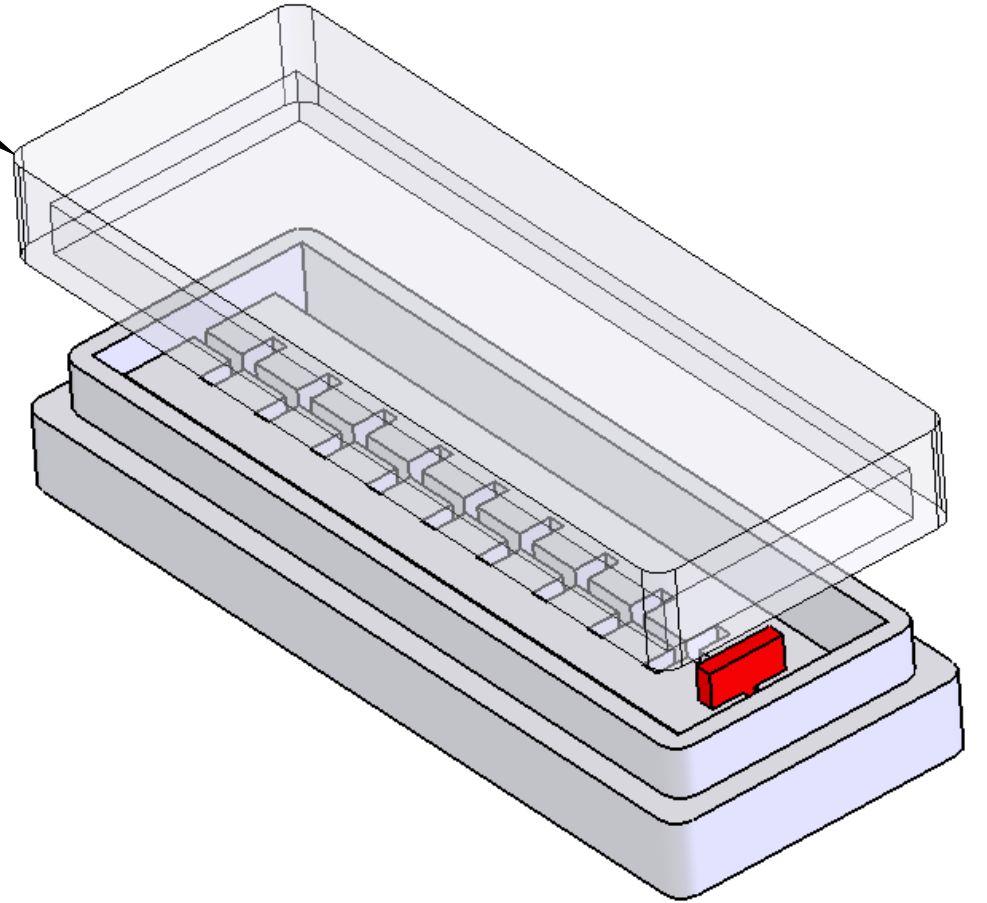

7 I HG 97 H C B 'K #k 'D 5 F H -B 'D @ 5 7 9

BchY.  
%&'A UHYf]U' Hc 'VY '\* ( [ # 'XYbg] hmf ( "\$ `V#zh 1'9DGž  
GhUj]W8 ]gg]dUj] Y  
&1%'8 Y[ fYY '8 fUZhiHMD  
' 1'8 ]a Ybg]cbg'g\ck b'UfY ']b'a ]`]a YHYfg

DFC DF-9 5 FM 5 B 8 7 CB : 8 9 B H 5 @  
H: 9 B : C FA 5 H C B 7 C B H 5 B 9 8 -B 1 k -G  
8 F 5 K B : -G H : 9 G C @ D F C D 9 F H M C :  
Vgo r q'Rrcule'E q0'Kpe0 5 B M  
F 9 D F C 8 I 7 H C B -B 'D 5 F H C F 5 G 5 K < C @  
K #k : C I H H : 9 K F H 9 B D 9 F A @ G C B C :  
Vgo r q'Rrcule'E q0'Kpe0 G  
D F C < 6 + 9 8 "

|                 |             |  |                   |                               |                                 |
|-----------------|-------------|--|-------------------|-------------------------------|---------------------------------|
|                 |             | I B @GG C H: 9FK @9 QD97 ÷ 98.   | B 5 A 9           | 8 5 H 9                       | <b>Vgo r q'Rrcule'E q0'Kpe0</b> |
|                 |             | 8 A 9 B G C B G 5 F 9 B 'B 7 < 9 G<br>H C @ F 5 B 7 9 G<br>: F 5 7 H C B 5 @±<br>5 B : I @ 5 F : A 5 7 < ± ..... 6 9 B 8 ±<br>H K C D @ 5 7 9 8 9 7 -A 5 @ ± ±<br>H : F 9 9 D @ 5 7 9 8 9 7 -A 5 @ ± ± | 8 F 5 K B         | G Y   Y b'<br>5 U l r c f f Y |                                 |
|                 |             | B H F D F 9 H : 9 C A 9 F 7<br>H C @ F 5 B 7 B : D 9 F .<br>A 5 H F F -5 @   | 7 < 9 7 ? 9 8     |                               | H H @ 9 .                       |
|                 |             | : B G <  | A : : ' 5 D D F " |                               | % \$ G   ) \$ \$                |
| B 9 L H 5 G G M | I G 9 8 C B |  | E " 5 "           |                               |                                 |
|                 |             | 5 D D @ 7 5 H C B  | 7 C A A 9 B H G   |                               | G A 9 8 K ; " " B C "           |
|                 |             | 8 C B C H G 7 5 @ 9 8 F 5 K B :  |                   |                               | F 9 J                           |
|                 |             |  |                   |                               | G 7 5 @ 9 . % %                 |
|                 |             |  |                   |                               | G < 9 9 H % C : %               |

8

7

6

5

8

7

6

5